

• General Description

The ZM031N04D combines advanced trench MOSFET technology with a low resistance package to provide extremely low $R_{DS(ON)}$.

• Features

- Advance high cell density Trench technology
- Low $R_{DS(ON)}$ to minimize conductive loss
- Low Gate Charge for fast switching
- Low Thermal resistance

• Application

- MB/VGA Vcore
- SMPS 2nd Synchronous Rectifier
- POL application
- BLDC Motor driver

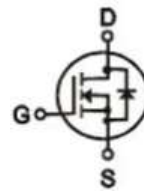
• Product Summary

$V_{DS}=40V$

$R_{DS(ON)} = 2.9m\Omega$

$I_D=120A$

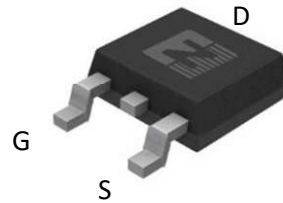

TO-252

• Ordering Information:

Part NO.	ZM031N04D
Marking	ZM031N04
Packing Information	REEL TAPE
Basic ordering unit (pcs)	2500

• Absolute Maximum Ratings ($T_C = 25^\circ C$)

Parameter	Symbol	Rating	Unit
Drain-Source Voltage	V_{DS}	40	V
Gate-Source Voltage	V_{GS}	± 20	V
Continuous Drain Current	$I_{D@TC=25^\circ C}$	120	A
	$I_{D@TC=75^\circ C}$	91.2	A
	$I_{D@TC=100^\circ C}$	75.6	A
Pulsed Drain Current ^①	I_{DM}	280	A
Total Power Dissipation($TC=25^\circ C$)	$P_{D@TC=25^\circ C}$	70	W
Total Power Dissipation($TA=25^\circ C$)	$P_{D@TA=25^\circ C}$	2.5	W
Operating Junction Temperature	T_J	-55 to 150	$^\circ C$
Storage Temperature	T_{STG}	-55 to 150	$^\circ C$
Single Pulse Avalanche Energy@ $L=0.1mH$	E_{AS}	180	mJ
Avalanche Current@ $L=0.1mH$	I_{AS}	60	A

●Thermal resistance

Parameter	Symbol	Min.	Typ.	Max.	Unit
Thermal resistance, junction - case	R_{thJC}	-	-	2.1	° C/W
Thermal resistance, junction - ambient	R_{thJA}	-	-	65	° C/W
Soldering temperature, wave soldering for 10s	T_{sold}	-	-	265	° C

●Electronic Characteristics

Parameter	Symbol	Condition	Min.	Typ	Max.	Unit
Drain-Source Breakdown Voltage	BV_{DSS}	$V_{GS} = 0V, I_D = 250\mu A$	40			V
Gate Threshold Voltage	$V_{GS(TH)}$	$V_{GS} = V_{DS}, I_D = 250\mu A$	1.2		2.5	V
Drain-Source Leakage Current	I_{DSS}	$V_{DS} = 40V, V_{GS} = 0V$			1.0	μA
Gate- Source Leakage Current	I_{GSS}	$V_{GS} = \pm 20V, V_{DS} = 0V$			± 100	nA
Static Drain-source On Resistance	$R_{DS(ON)}$	$V_{GS} = 10V, I_D = 24A$		2.9	4	m Ω
		$V_{GS} = 4.5V, I_D = 12A$		3.9	5.5	m Ω
Forward Trans conductance	g_{FS}	$V_{DS} = 25V, I_D = 10A$		16		s
Source-drain voltage	V_{SD}	$I_S = 24A$			1.28	V

●Electronic Characteristics

Parameter	Symbol	Condition	Min.	Typ	Max.	Unit
Input capacitance	C_{iss}	f = 1MHz VDS=25V	-	4800	-	pF
Output capacitance	C_{oss}		-	460	-	
Reverse transfer capacitance	C_{rss}		-	240	-	

●Gate Charge characteristics($T_a = 25^\circ C$)

Parameter	Symbol	Condition	Min.	Typ	Max.	Unit
Total gate charge	Q_g	$V_{DD} = 25V$	-	55	-	nC
Gate - Source charge	Q_{gs}	$I_D = 20A$	-	12	-	
Gate - Drain charge	Q_{gd}	$V_{GS} = 10V$	-	15	-	

Note: ① Pulse Test : Pulse width $\leq 300\mu s$, Duty cycle $\leq 2\%$;

Fig.1 Power Dissipation

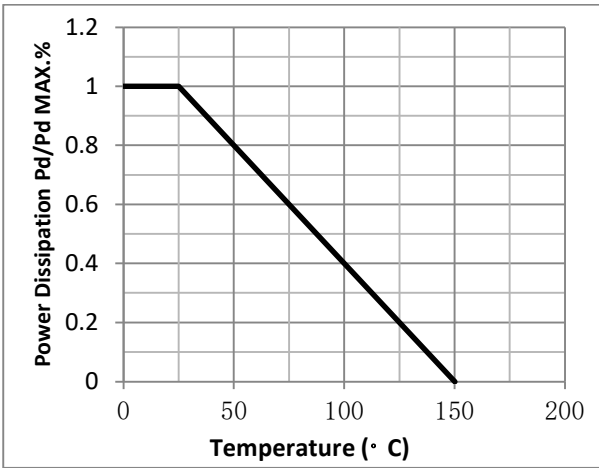

Fig.2 Typical output Characteristics

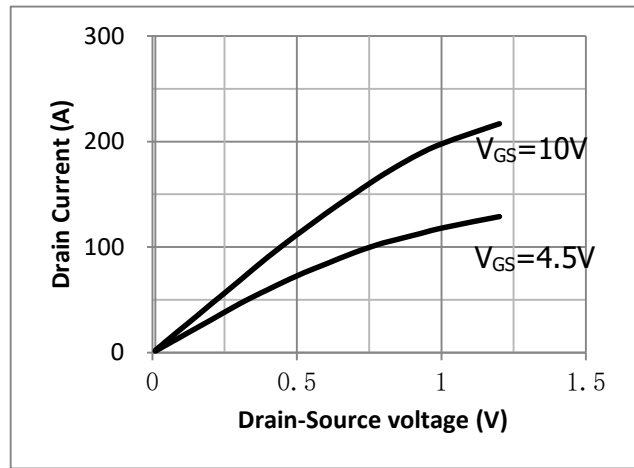

Fig.3 Threshold Voltage V.S Junction Temperature

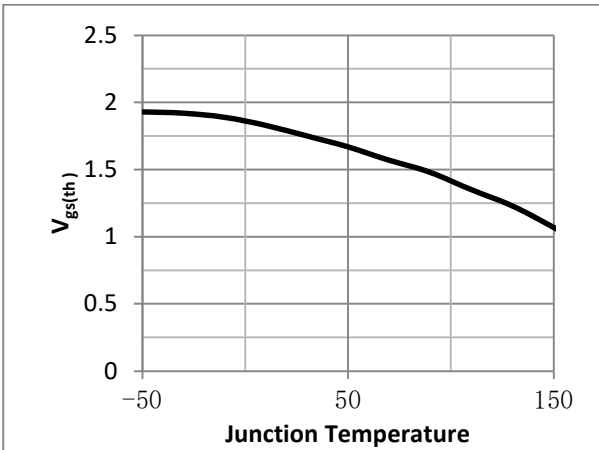

Fig.4 Resistance V.S Drain Current

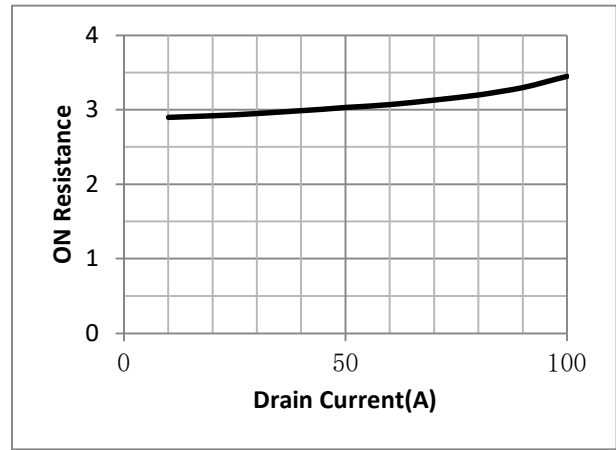

Fig.5 On-Resistance VS Gate Source Voltage

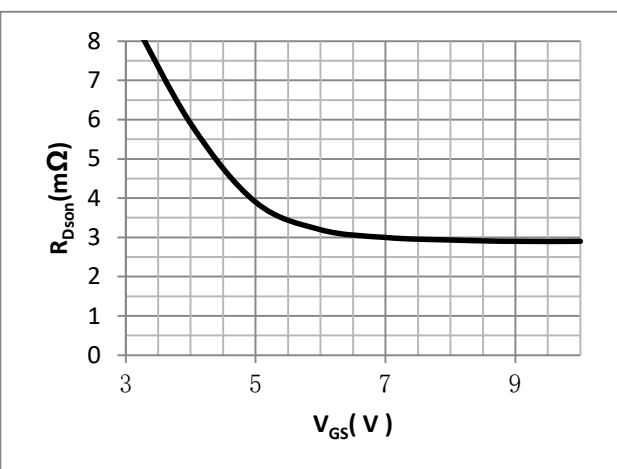

Fig.6 On-Resistance V.S Junction Temperature

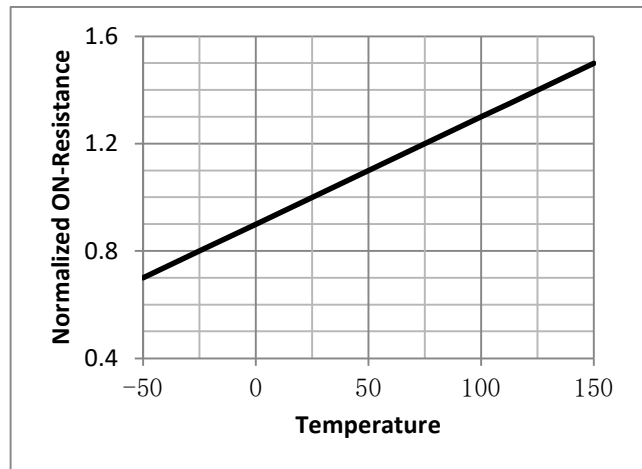

Fig.7 Switching Time Measurement Circuit

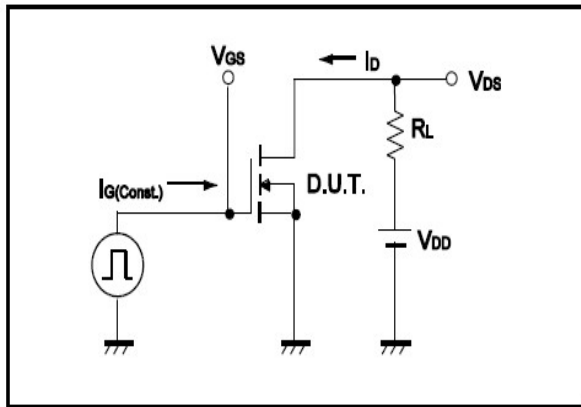

Fig.8 Gate Charge Waveform

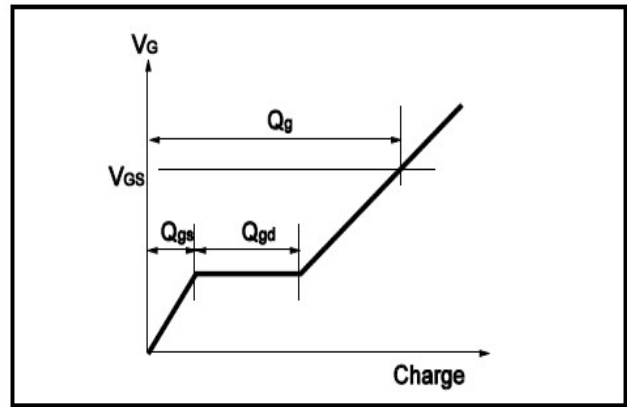

Fig.9 Switching Time Measurement Circuit

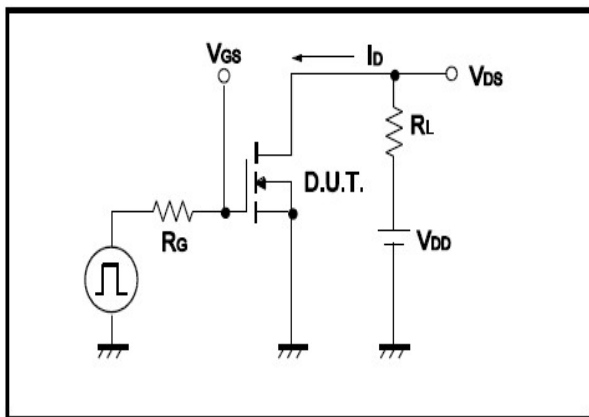

Fig.10 Gate Charge Waveform

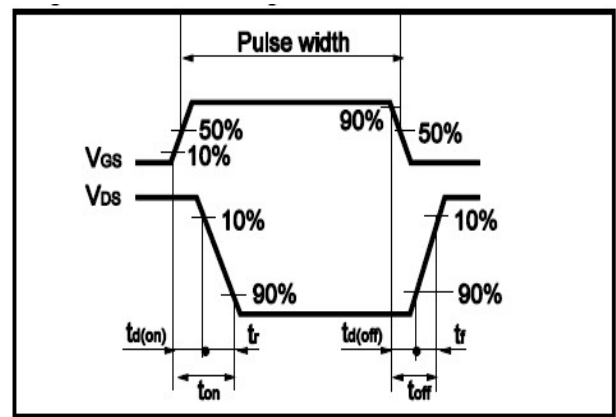

Fig.11 Avalanche Measurement Circuit

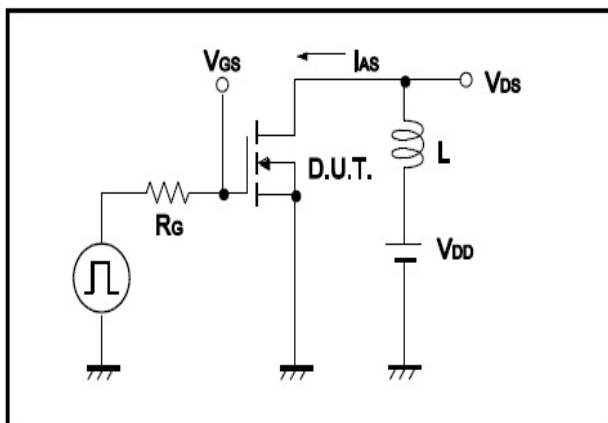
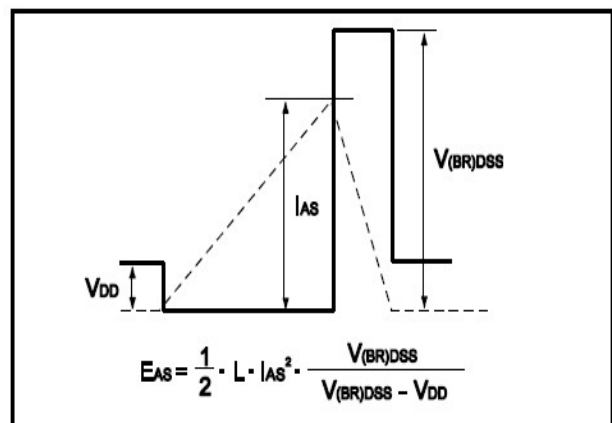
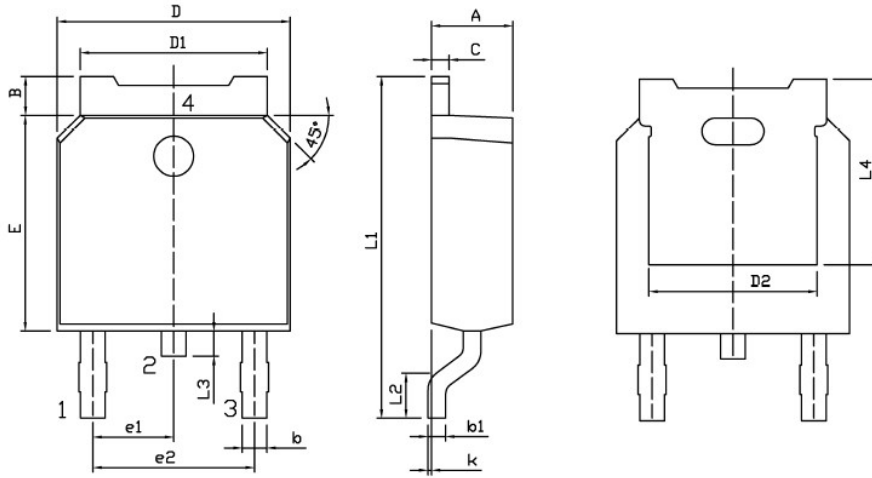

Fig.12 Avalanche Waveform





•Dimensions (TO-252)



Land Pattern
(Only for Reference)

Dimensions In Millimeters					
Symbol	MIN	MAX	Symbol	MIN	MAX
A	2.20	2.40	E	5.95	6.25
B	0.95	1.25	e1	2.24	2.34
b	0.70	0.90	e2	4.43	4.73
b1	0.45	0.55	L1	9.85	10.35
C	0.45	0.55	L2	1.70	2.00
D	6.45	6.75	L3	0.60	0.90
D1	5.10	5.50	L4	5.05	
D2	4.85		k	0.00	0.10

